

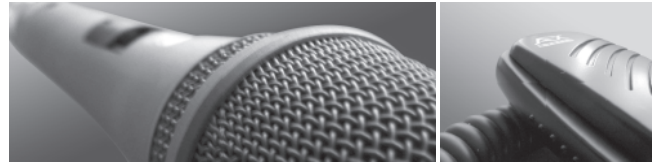

Protecting Your Human Assets During Emergency

MH 1a, MH 2a & ME 1 Microphone - Emergency and Handheld



The single most important criteria for an emergency paging microphone is its ability to pick up and transmit voice signal clearly while minimising unwanted noise. The ME 1 Emergency Microphone is designed with the frequency response aimed at capturing voice effectively. It is connected to the mixer via a 5-pin microphone plug for signal and priority activation with a single push button. Its coiled cable provides ample length without taking up space and fits in neatly within the equipment rack.

For stage and studio usage, the MH 1a and MH 2a Handheld Microphones are the best choice for sound quality and performance. Its robust casing of diecasted zinc alloy coupled with an integrated shock-mount system is able to withstand rough usage as well as reducing handling noise. The unidirectional cardioid pick-up pattern ensures optimal signal pick-up from the vocalist while dampening unwanted background noise. The two models offer different frequency response to cater for individual needs. activation is by means of a pop-free slide switch for uninterrupted operation.

ME 1

- Unidirectional dynamic microphone with built-in push-to-talk switch.
- Hand-held type.
- 600 ohm output impedance.
- Frequency response tailored for speech reproduction.
- Comes with coiled cable, 5-pin microphone plug and mounting bracket.

MH 1a & MH 2a

- Unidirectional dynamic microphone with built-in slide switch that prevents switch-on pop.
- Minimal handling noise.
- 600 ohm output impedance.
- Cardioid / Super Cardioid characteristics helps reduce background noise pick up and feedback.
- Comes with 5 m microphone cable.



MH 1a



MH 2a



ME 1



Technical Specifications

	MH 1a	MH 2a	ME 1
Type	Dynamic microphone	Dynamic microphone	Dynamic microphone
Polar Pattern	Unidirectional, Cardioid	Unidirectional, Super Cardioid	Unidirectional
Frequency Response	50 Hz ~ 15 kHz	50 Hz ~ 16 kHz	300 Hz ~ 8 kHz
Output Impedance	600 Ω unbalanced (at 1 kHz)	600 Ω unbalanced (at 1 kHz)	600 Ω unbalanced (at 1 kHz)
Output Level	-72 dB +/- 3 dB (at 1 kHz)	-72 dB +/- 3 dB (at 1 kHz)	-72 dB +/- 3 dB (at 1 kHz)
Magnet Type	Neodymium	Neodymium	Ferrite
Capsule Type	29 mm Dynamic Moving Coil	29 mm Dynamic Moving Coil	24 mm Dynamic Moving Coil
Cable	5 m Microphone Cable (3 pin XLR (F) to 1/4" mono Phone Jack)	5 m Microphone Cable (3 pin XLR (F) to 1/4" mono Phone Jack)	Coiled cable, 3 core & 1 screen x 1.4 m (at a max extended length)
Switch	Slide switch (Pop-Free)	Slide switch (Pop-Free)	Push-to-talk switch
Dimensions	Dia 53 x 180 mm	Dia 53 x 185 mm	58 x 80 mm
Material & Finish	Diecasted zinc alloy with steel mesh. metallic quartz grey/silver	Diecasted zinc alloy with steel mesh. metallic quartz grey/silver	ABS. matt black & grey
Weight	0.29 kg	0.29 kg	0.12 kg

Block Diagram

ME 1

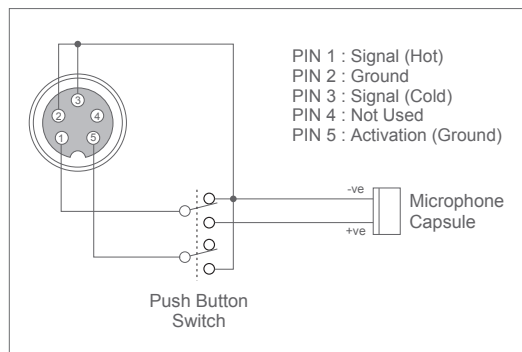

SPL Polar Plot for MH 1a & MH 2a

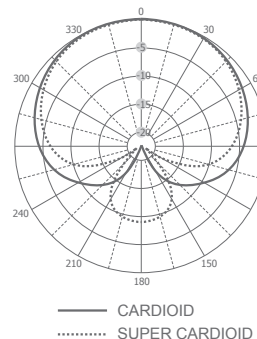

Engineers' Specifications

ME 1

The emergency microphone shall be of a unidirectional dynamic moving coil type, with an unbalanced output of -72 db, 600 ohm and uniform frequency response between 300 Hz ~ 8 kHz. There shall be a built-in push-to-talk switch on the unit. It shall come with a coiled cable and 5-pin microphone plug. The dimensions of the unit shall not exceed 58 x 80 mm and weight not exceeding 0.12 kg.

MH 1a / MH 2a

The unidirectional handheld microphone shall be of a dynamic moving coil type, with an unbalanced output of -72 dB, 600 Ω and uniform frequency response between 50 Hz ~ 15 kHz (MH 1a) / 50 Hz ~ 16 kHz (MH 2a). The microphone shall be fitted with a 29 mm cardioid (MH 1a) / Super Cardioid (MH 2a) neodymium dynamic moving coil capsule. There shall be pop-free slide switch and an integrated shock-mount system to reduce handling noise. The dimensions of the unit shall not exceed dia. 53 x 180 mm (MH 1a) / dia. 53 x 185 mm (MH 2a) and weight not exceeding 0.29 kg.



MH 1a



MH 2a

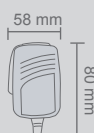

ME 1